

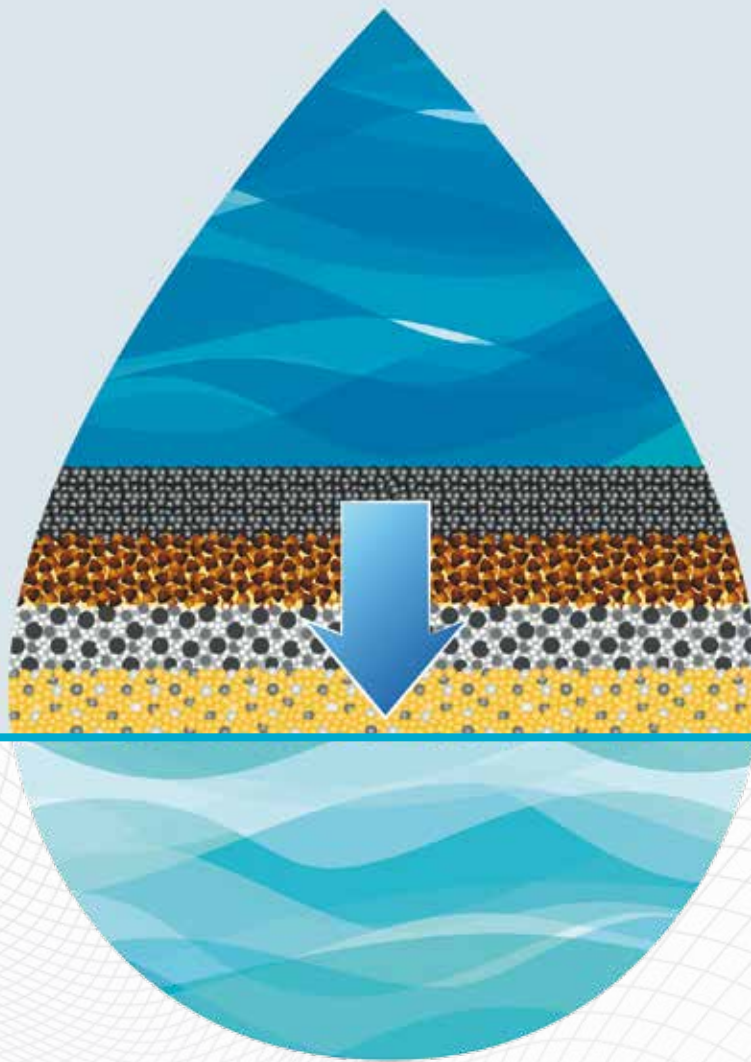

TRESA

H

EFFLUENT TREATMENT SOLUTION
FOR HEMATOLOGY ANALYSERS



TRESA^H

PRODUCT OVERVIEW

The TRESA^H treatment unit is a biohazardous decontamination system designed to treat highly concentrated effluents and wastewater generated by hematology analysers

TRESA^H unit can efficiently treat large volume through the application of dilution and two power UV-C lamps that decontaminate the effluent before getting released into the sewer system. TRESA^H is a compact and mobile treatment unit that can be placed next or behind hematology analysers in laboratories with limited space availability.



ABOUT MAUMEE SCIENTIFIC

Maumee Scientifics is a Swiss company dedicated to tackling the environmental challenges faced in the medical industry. Our goal is to introduce new technologies that are environmentally friendly and provide solutions for waste discharge that suits any medical environment.

TECHNICAL SPECIFICATION

STORAGE TANK	Electropolished 316 L stainless steel
DIMENSIONS	Height: 624 mm / Length: 726 mm / Width: 360 mm
WEIGHT	35 Kg
UV REACTOR	Electropolished 316 L stainless steel
UV POWER	2 x 95 W
UV LAMP LIFE	Up to 9,000 hours of operation
MAXIMUM PUMP FLOW	< 12 l/min at 1 bar
POWER CONSUMPTION	300 W
DILUTION LEVEL	1:10
TREATMENT CAPACITY	Up to 12 l/h

UTILITIES REQUIREMENTS

CITY WATER SUPPLY	Min pressure = 1 bar - max pressure = 3 bars
ELECTRICITY	220V, 1.36 Amps, single phase
CONNECTION TO THE SEWER SYSTEM	Diameter 40 mm, located at less than 2 m from the unit and at a height below 30 cm
PIPING	Ensure sufficient length between the output of the automated unit and the TRESA ^H unit

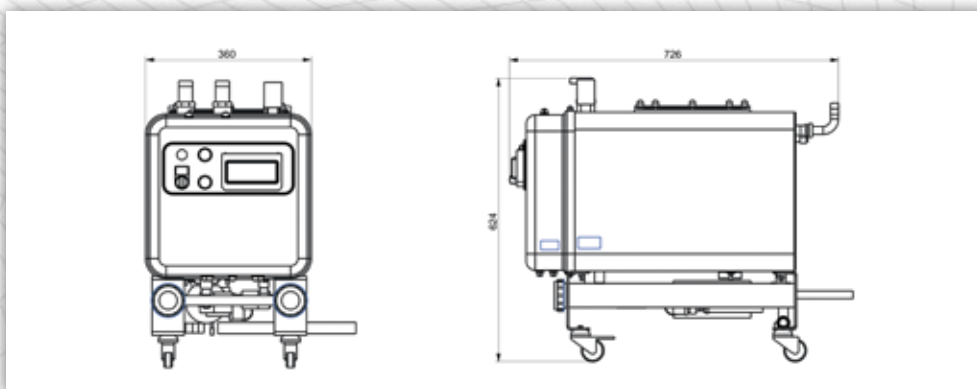

PROCESS DESCRIPTION

By gravity, the effluent from the hematology analysers start to fill gradually the holding tank of the TRESA^H Unit, flowing through a check valve, while the air is removed by the vent.

Once a certain level is reached in the holding tank an electrovalve opens to complete the filling with water to obtain a certain dilution level.

The UV-C lamps are turned on and preheated to reach their optimum output. An extraction pump will push the effluent that will circulate through the two UV-C lamps before getting discharged into the sewer drain.



Decontamination System compliant with CE Norms EN 61326 A1/A2/A3 & EN 61010-1



Avenue Reverdil, 4 - 1260, Nyon - Switzerland
info@maumeescientific.com - www.maumeescientific.com