

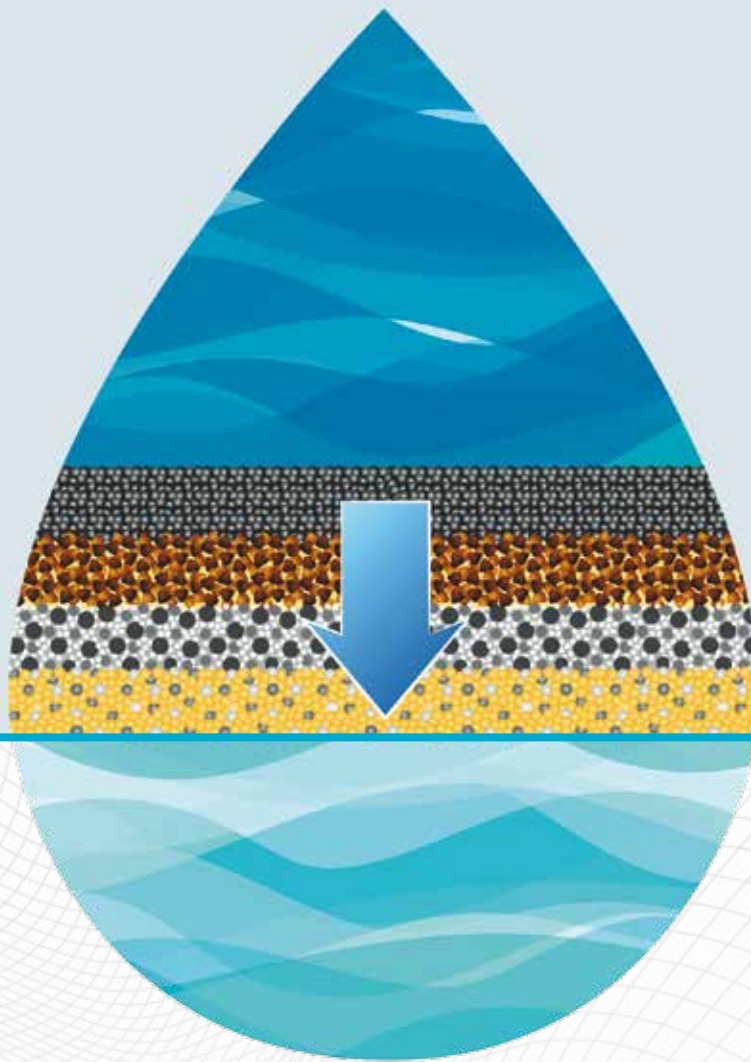

# TRESA

# CI

EFFLUENT TREATMENT SOLUTION  
FOR BIOCHEMISTRY IMMUNO ANALYZERS



# TRESA

# CI

## PRODUCT OVERVIEW

**The TRESA<sup>CI</sup> treatment unit is a biohazardous decontamination system designed to treat highly concentrated effluents and wastewater generated by biochemistry immuno analyzers.**

TRESA<sup>CI</sup> unit can efficiently treat large volume through the application of dilution and two power UV-C lamps that decontaminate the effluent before getting released into the sewer system. TRESA<sup>CI</sup> is a compact and mobile treatment unit that can be placed next or behind biochemistry immuno analyzers in laboratories with limited space availability.



ABOUT  MAUMEE  
SCIENTIFIC

Maumee Scientifics is a Swiss company dedicated to tackling the environmental challenges faced in the medical industry. Our goal is to introduce new technologies that are environmentally friendly and provide solutions for waste discharge that suits any medical environment.

## TECHNICAL SPECIFICATION

|                    |   |
|--------------------|---|
| STORAGE TANK       | Electropolished 316 L stainless steel           |
| DIMENSIONS         | Height: 624 mm / Length: 726 mm / Width: 360 mm |
| WEIGHT             | 35 Kg   |
| UV REACTOR         | Electropolished 316 L stainless steel           |
| UV POWER           | 2 x 95 W  |
| UV LAMP LIFE       | Up to 9,000 hours of operation                  |
| MAXIMUM PUMP FLOW  | < 12 l/min at 1 bar                             |
| POWER CONSUMPTION  | 300 W   |
| DILUTION LEVEL     | 1:2   |
| TREATMENT CAPACITY | Up to 60 l/h                                    |

## UTILITIES REQUIREMENTS

|                                |  |
|--------------------------------|--|
| CITY WATER SUPPLY              | Min pressure = 1 bar - max pressure = 3 bars   |
| ELECTRICITY                    | 220V, 1.36 Amps, single phase  |
| CONNECTION TO THE SEWER SYSTEM | Diameter 40 mm, located at less than 2 m from the unit and at a height below 30 cm                 |
| PIPING                         | Ensure sufficient length between the output of the automated unit and the TRESA <sup>CI</sup> unit |

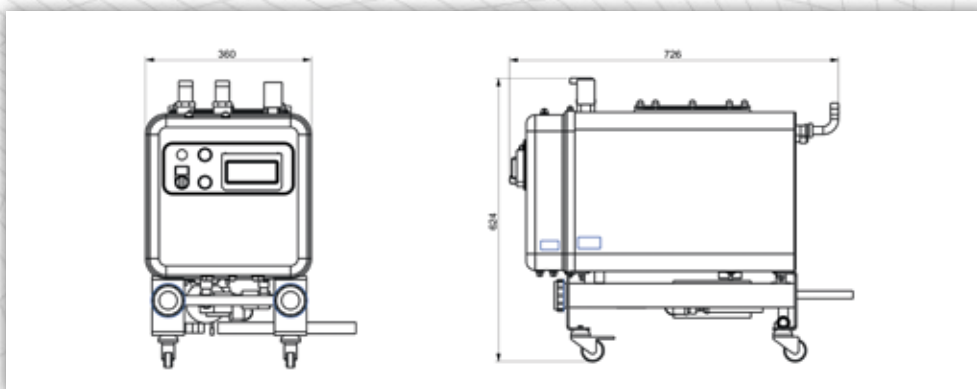

## PROCESS DESCRIPTION

By gravity, the effluent from the biochemistry immuno analyzer start to fill gradually the holding tank of the TRESA<sup>CI</sup> Unit, flowing through a check valve, while the air is removed by the vent.

Once a certain level is reached in the holding tank an electrovalve opens to complete the filling with water to obtain a certain dilution level.

The UV-C lamps are turned on and preheated to reach their optimum output. An extraction pump will push the effluent that will circulate through the two UV-C lamps before getting discharged into the sewer drain.



Decontamination System compliant with CE Norms EN 61326 A1/A2/A3 & EN 61010-1



Avenue Reverdil, 4 - 1260, Nyon - Switzerland  
info@maumeescientific.com - www.maumeescientific.com